

**SIDE VIEW RETRACTED**

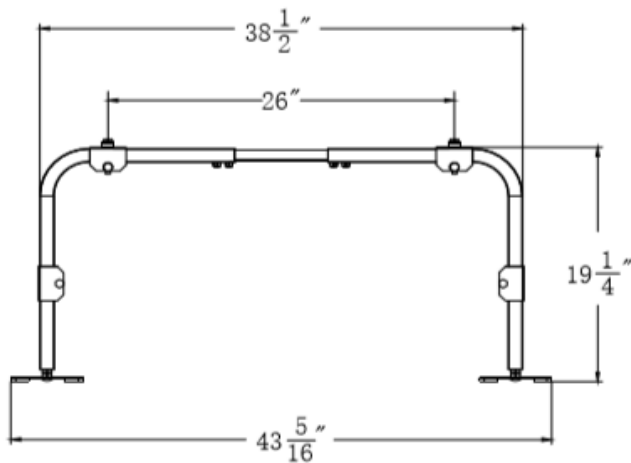

**SIDE VIEW EXPANDED**

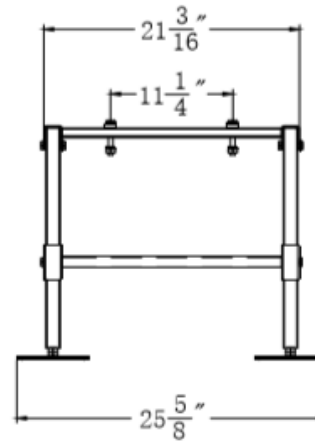

**END VIEW RETRACTED**

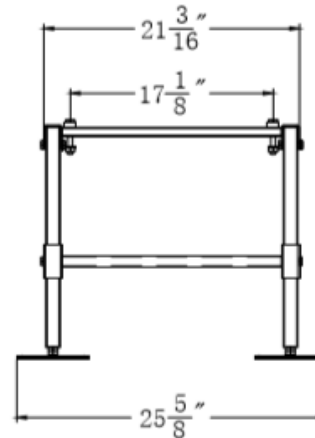

**END VIEW EXPANDED**

(\*)- WIDTH IS ADJUSTABLE IN 1" INCREMENTS  
 IMPORTANT NOTE: THE INSTALLER IS RESPONSIBLE FOR THETHERING AND BOLTING UNITS TO WITHSTAND WIND AND/OR SEISMIC LOADS.

UNLESS OTHERWISE SPECIFIED:  
 DIMENSIONS ARE IN INCHES (MILLIMETERS)  
 TOLERANCES ARE: ANGLES ±1.0°  
 FRACTIONAL SIZES XY/Z ±.004  
 INCHES (MILLIMETERS)  
 X = ±0.1 [ X = ±0.25 ]  
 XX = ±0.01 [ X = ±0.15 ]  
 XXX = ±0.005 [ XX = ±0.15 ] THRD ANGLE INCLINATION



DWG. NO:  
 MINI SPLIT STAND -1801  
 IBEX 1801

**VIEW**

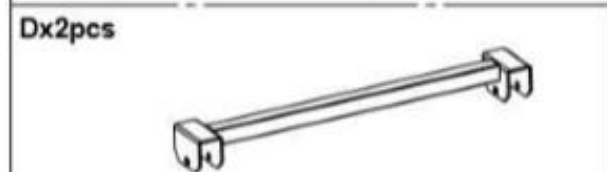
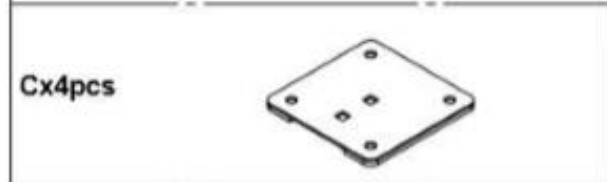
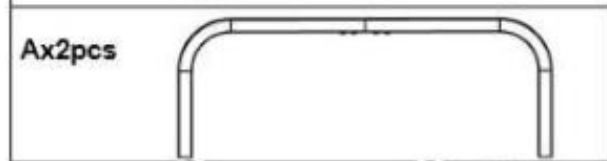
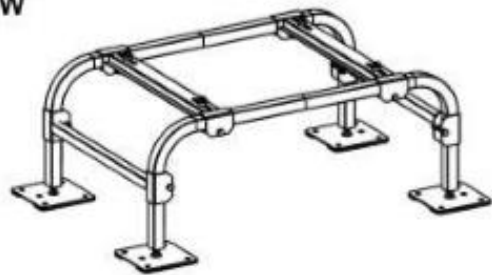

1	Carriage bolt M10x50		x4
2	Hex bolt M10x50		x12
3	Nut		x20
4	Washer M10		x8
5	Rubber washer		x4
6	Rubber bonded washer M10		x4
7	Lock washer		x12

**ASSEMBLY INSTRUCTION**

Model: 1801 , 1802, 2401, 2402

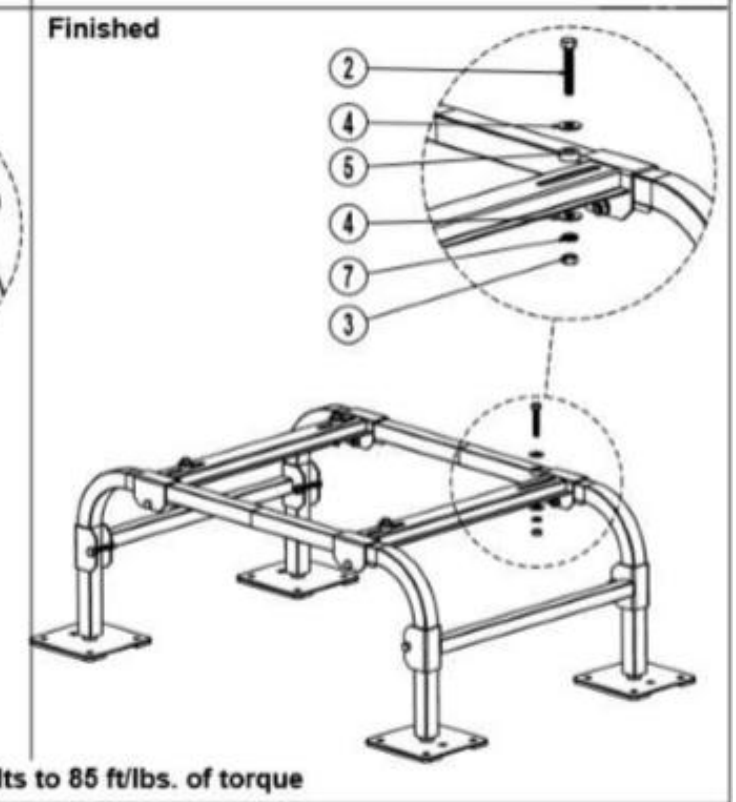
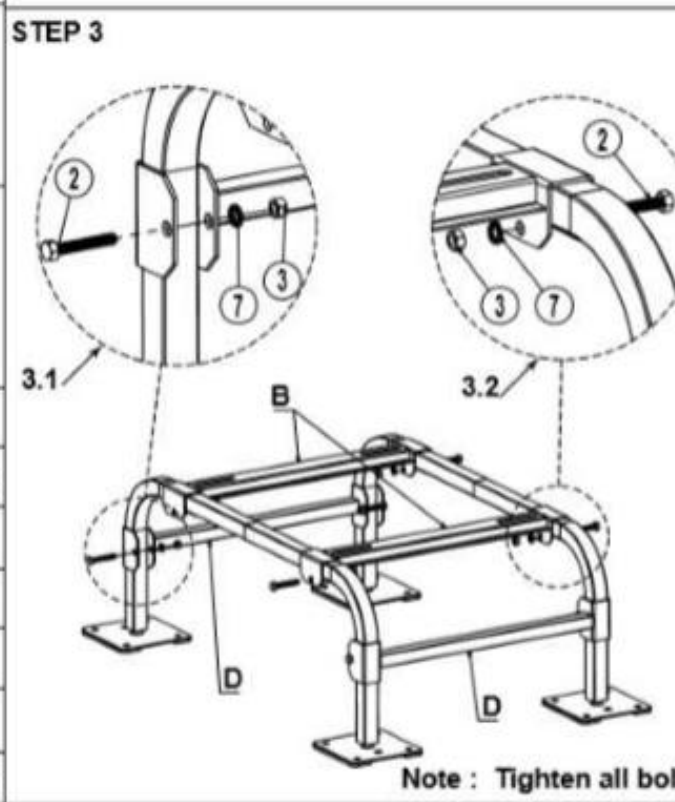
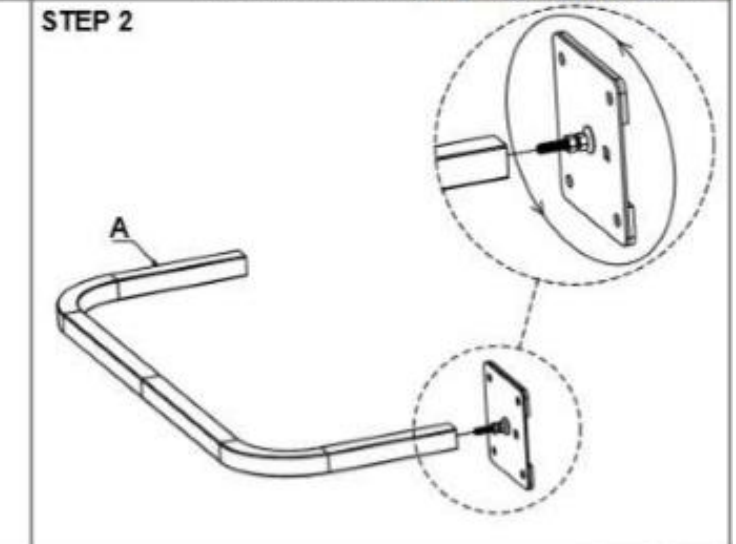
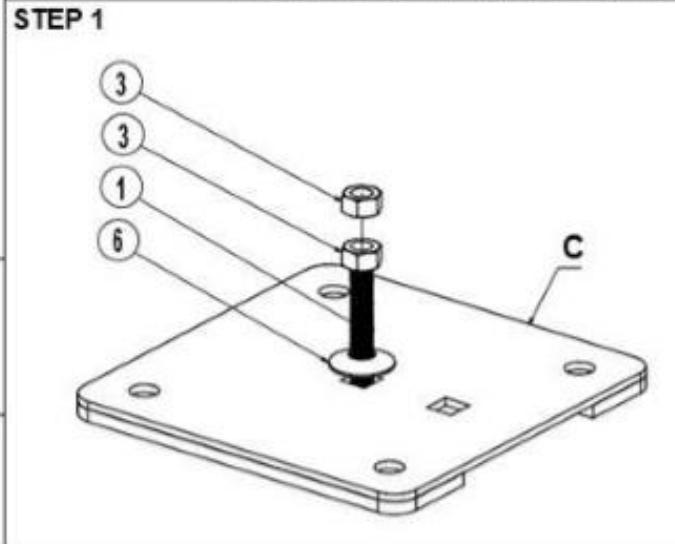

Note : Tighten all bolts to 85 ft/lbs. of torque